

RULLO BETA3 TUBO ACCIAIO 1P-1PF (T8 Z20) BETA3 ROLLER STEEL TUBE 1P-1PF (T8-Z20)

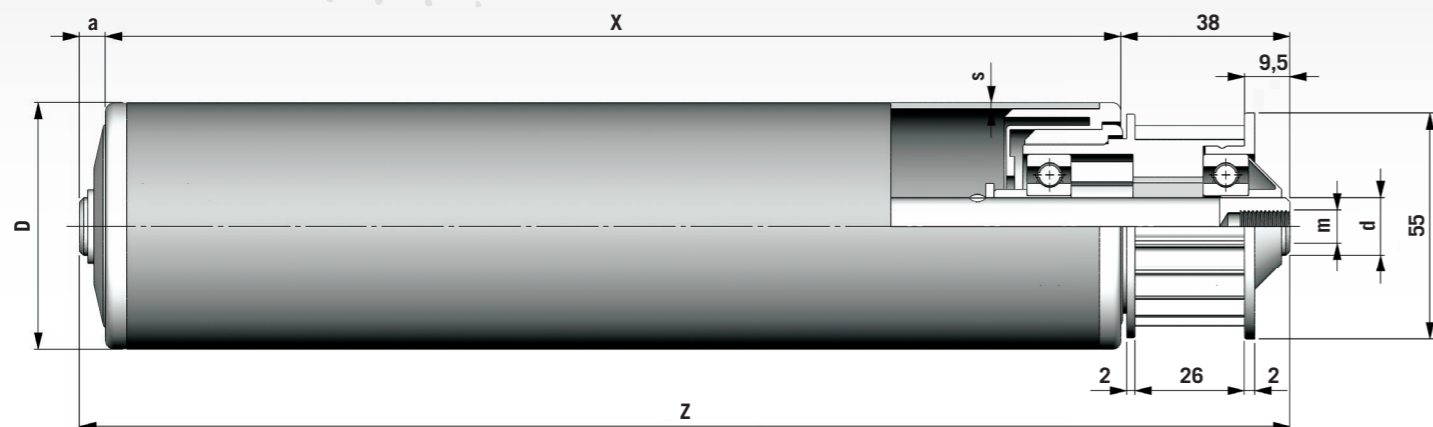

EXEC B2 ASSE 14 - EXEC B2 SHAFT 14

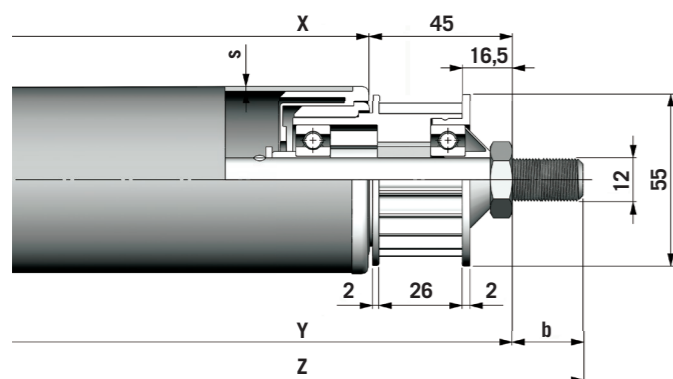

EXEC C ASSE 12 - EXEC C SHAFT 12

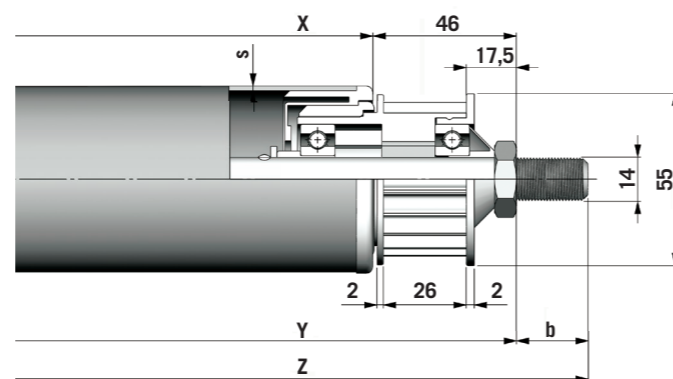

EXEC C ASSE 14 - EXEC C SHAFT 14

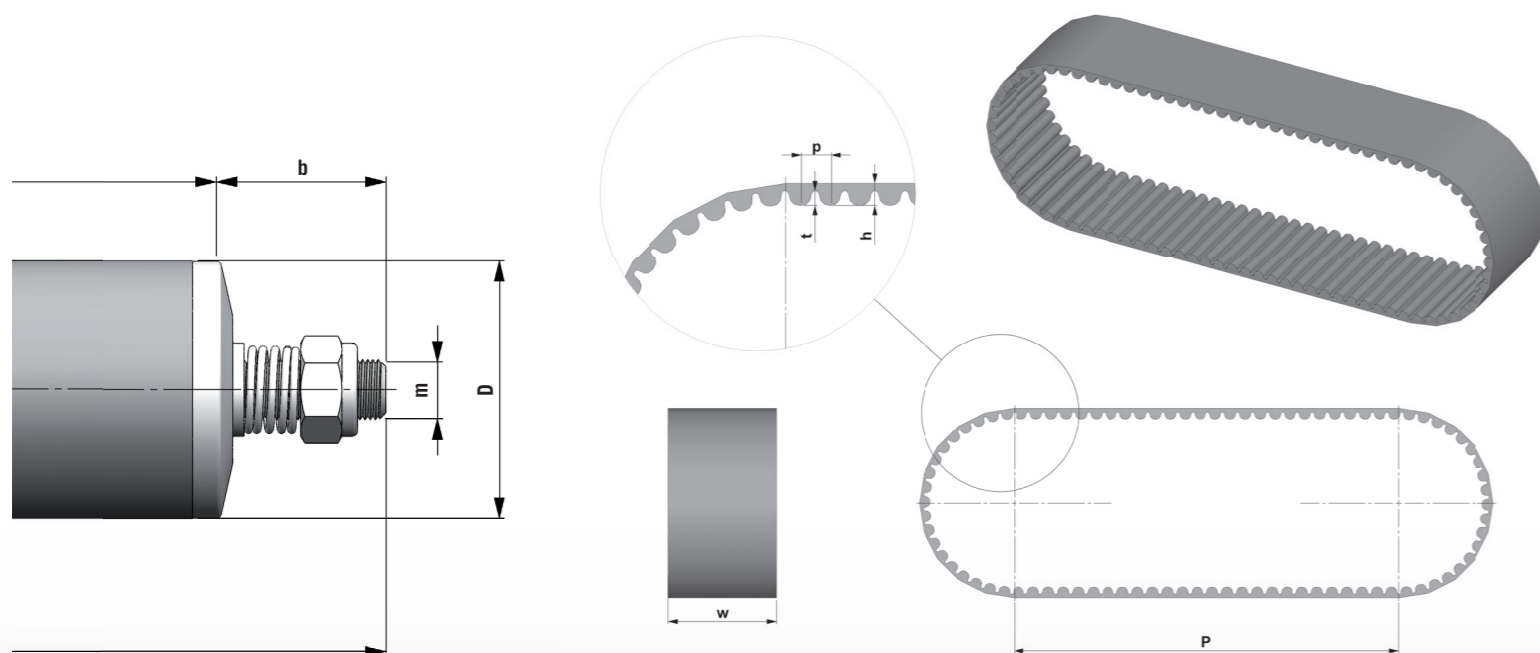

Frizione registrabile
Adjustable frictioned pulley

Cinghie Dentata Polychain
Toothed Belt Polychain

RULLO BETA3 TUBO ACCIAIO 1P-1PF (T8 Z20) BETA3 ROLLER STEEL TUBE 1P-1PF (T8-Z20)

TIPO TYPE	ESEC. ASSE SHAFT CONFIG.	DIMENSIONI - DIMENSIONS						PESO (KG) WEIGHT (KG)	
		a	b	m	D	d	s	X=200	Al mm - Per mm
50/12	B	5		8x15	50	12	1.5	0.813	0.00268
	C	12	18	12					
60/12	B	5		8x15	60	12	1.5	0.935	0.00305
	C	12	18	12					
70/12	B	5		8x15	70	12	2	1.025	0.00342
	C	12	18	12					
80/12	B	5		8x15	80	12	2	1.321	0.00473
	C	12	18	12					
50/14	B	5		10x15	50	14	1.5	0.917	0.00300
	C	13	22	14					
60/14	B	5		10x15	60	14	1.5	1.039	0.00337
	C	13	22	14					
70/14	B	5		10x15	70	14	2	1.129	0.00374
	C	13	22	14					
80/14	B	5		10x15	80	14	2	1.425	0.00505
	C	13	22	14					

ESECUZIONI A RICHIESTA	AVAILABLE OPTIONS
Esecuzioni assi diverse	Other shaft configurations
Asse acciaio inox	Stainless steel shafts
Asse acciaio zincato	Galvanized steel Shafts
Asse acciaio esagonale	Hexagonal steel Shafts
Tubo acciaio inox	Stainless Steel Tube
Tubo acciaio zincato	Galvanized Steel Tube
Tubo acciaio rilsanzato	Rilsan coating steel Tube
Tubo alluminio	Aluminum Tube
Puleggia acciaio	Steel pulley
Puleggia acciaio inox	Stainless steel pulley
Cuscinetto acciaio inox	Stainless steel bearing
Frizione registrabile	Adjustable frictioned pulley

CINGHIE DENTATE DISPONIBILI A MAGAZZINO SPURRED CHAINS IN STOCK

CINGHIE DENTATE TIPO POLYCHAIN TOOTHED BELT POLYCHAIN TYPE	Passo P - Pitch P							p	t	h	w
	64	96	128	160	192	224	240				
Lunghezza - Length	288	352	416	480	544	608	640	8	3,2	5,4	12
N° di denti - N. Teeth	36	44	52	60	68	76	80	8	3,2	5,4	12

Vedere disegno allegato "Cinghie Dentata Polychain"
See attached Drawing "Toothed belt Polychain"