

SERIE 600

SERIES 600

NASTRI TRASPORTATORI
BELT CONVEYORS



SUPPORTI - NASTRI TRASPORTATORI
SUPPORTS - BELT CONVEYORS

SERIE 600

SERIES 600

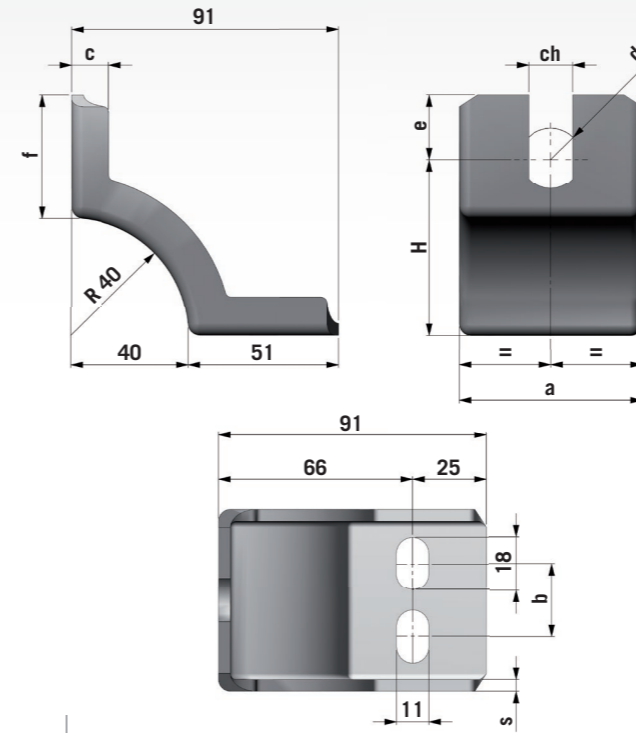

Supporto 600.1 per stazioni superiori
Support 600.1 for upper stations

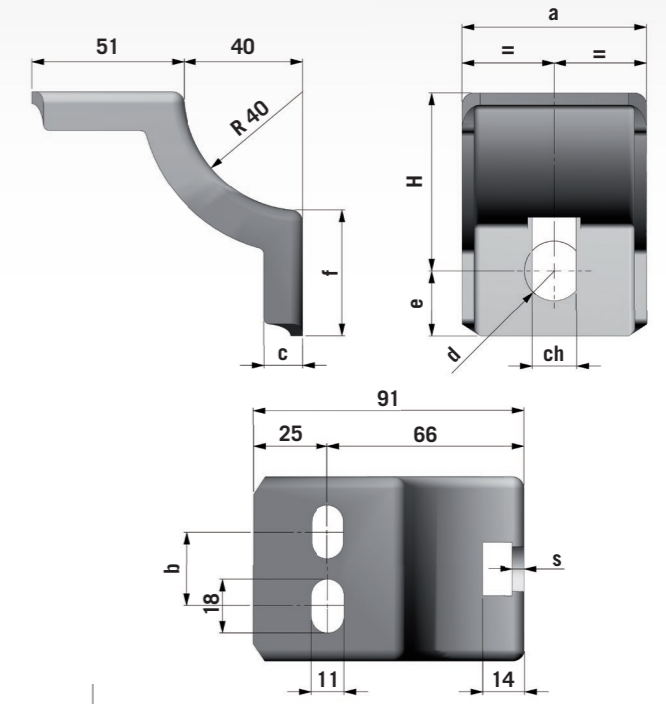

Supporto 600.3 per stazioni inferiori
Support 600.3 for lower stations

TIPO TYPE	d	ch	DIMENSIONI - DIMENSIONS							PESO (KG) WEIGHT (KG)
			H	a	b	c	e	f	s	
600.1	20	15-17	60	62	25	13	22	42	4	0,210
600.2	20		80							0,290
600.11	25	18	100	90	35	15	30	60	5	0,720
600.21	25		120							0,800
600.3	20	15-17	60	62	25	13	22	42	4	0,220
600.4	20		80							0,300
600.31	30	22	100	90	35	15	30	60	5	0,735
600.41	30		120							0,815