

RULLO CONICO ALFA/GAMMA ALFA/GAMMA TAPERED ROLLER

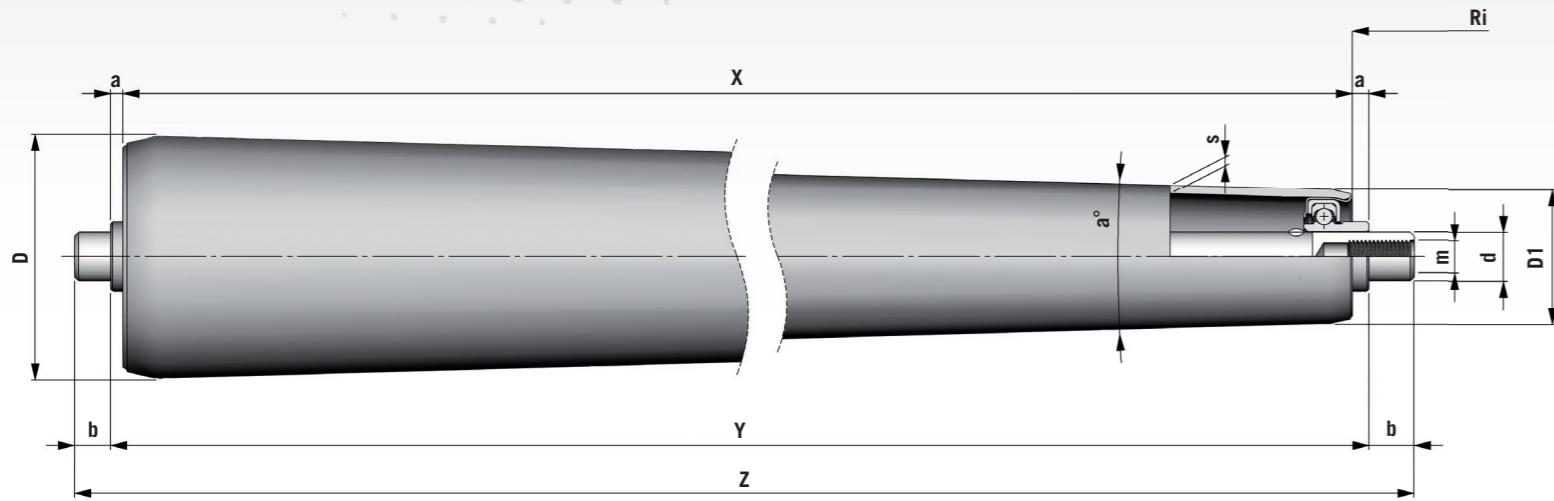

EXEC B2 ACCIAIO
 EXEC B2 STEEL

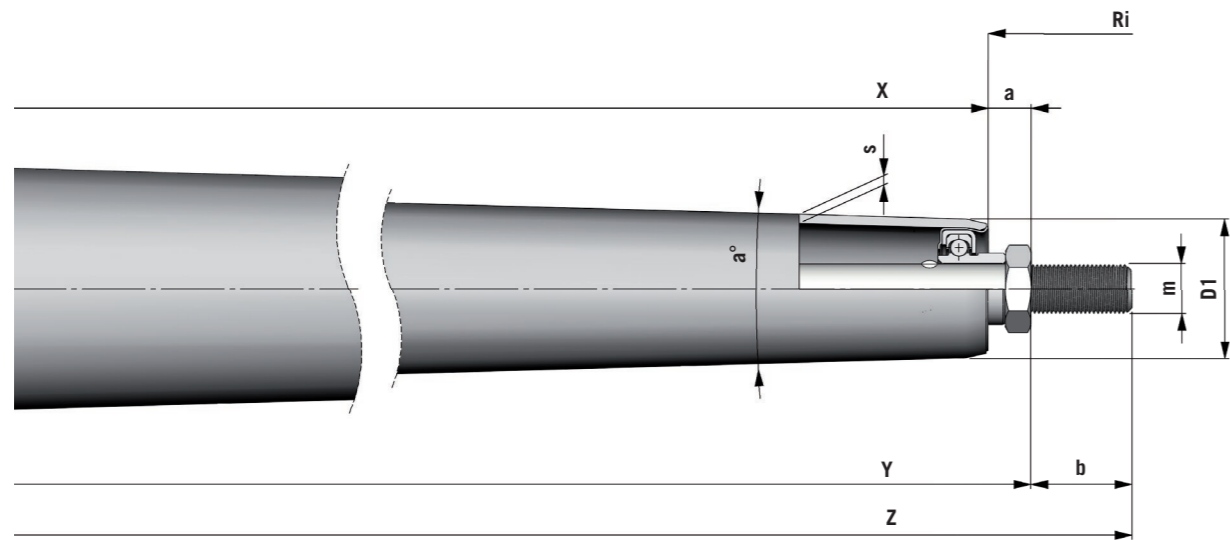

EXEC C ACCIAIO
 EXEC C STEEL

RULLO CONICO ALFA/GAMMA ALFA/GAMMA TAPERED ROLLER

X	TIPO TYPE	ESEC. ASSE SHAFT CONFIG.	DIMENSIONI - DIMENSIONS						s	Ri	a (°)	PESO (KG) WEIGHT (KG)
			a	b	m	D	D1	d				
300	50/34	B2	3	10	8x15	50	34	12	1.5	595	3.27	0.964
		B3	3	10	12							
		C	10	20	12							
400	60/41	B2	3	10	8x15	60	41	12	1.5	820	2.86	1.390
		B3	3	10	12							
		C	10	20	12							
500	60/36	B2	3	10	8x15	60	36	12	1.5	720	2.86	1.695
		B3	3	10	12							
		C	10	20	12							
600	60/31	B2	3	10	8x15	60	31	12	1.5	620	2.86	2.000
		B3	3	10	12							
		C	10	20	12							
700	60/38	B2	3	10	8x15	60	38	12	1.5	1160	1.87	2.305
		B3	3	10	12							
		C	10	20	12							
800	60/34,5	B2	3	10	8x15	60	34.5	12	1.5	1060	1.87	2.610
		B3	3	10	12							
		C	10	20	12							
900	60/31	B2	3	10	8x15	60	31	12	1.5	960	1.87	2.915
		B3	3	10	12							
		C	10	20	12							

ESECUZIONI A RICHIESTA	AVAILABLE OPTIONS
Diametri di assi e tubi diversi	Different shaft and tube diameters
Esecuzioni assi diverse	Different shaft configurations
Lunghezze diverse	Different lengths
Conicità diverse	Different taperings
Raggi interni diversi	Different internal radius
Asse acciaio zincato	Galvanized steel shafts
Tubo acciaio zincato	Galvanized steel tubes
Cuscinetto acciaio inox	Stainless steel bearings